



reventon
INDUSTRIAL SOLUTIONS

Technical documentation
Destratification fan HC-3S



1. INTRODUCTION

- 1.1 PRECAUTIONS
- 1.2 TRANSPORT
- 1.3 PACKAGE CONTENT
- 1.4 USE

2. DEVICE CHARACTERISTICS

- 2.1 CONSTRUCTION AND PRINCIPLE OF OPERATION
- 2.2 DEVICE DIMENSIONS
- 2.3 DEVICE TECHNICAL DATA

3. ASSEMBLY

- 3.1 GENERAL PRINCIPLES
- 3.2 ROTATING MOUNTING BRACKET

4. INSTALLATION INSTRUCTIONS

- 4.1 CONNECTION OF THE DEVICE TO THE ELECTRICAL SYSTEM

5. PRECAUTIONS & WARNINGS

6. CONTROLS

7. CONNECTION SCHEMES

8. TERMS OF WARRANTY

1. INTRODUCTION

Thank you very much for purchasing destratification fan HC-3S. We would like to congratulate you on excellent choice. Please read and keep this manual.

1.1 PRECAUTIONS

The buyer and the user of the destratification fan Reventon Group brand should read carefully the following instructions and proceed to the content recommendations. Proceeding due to the following instruction guarantees the correct usage and safety. In case of any doubts please contact directly Reventon Group sp. z o. o. [Ltd.]. The producer reserves the rights to make changes to the technical documentation without previous notice. Reventon Group sp. z o. o. [Ltd.] is not responsible for the damages which occur due to improper installation, not keeping the device in repair or using the device out of line. The installation should be carried out by the professional installers, who possess the qualifications to install these types of devices. The installers are responsible for making the installation as instructed in the technical data. In case of unserviceable please plug out the device and contact with the authorized for repair person or the supplier. During the installation, use, service and periodical inspections all regulations and safety rules must be followed.

1.2 TRANSPORT

During the acceptance of goods, it is needed to check the device to exclude any damages. During the transport, it is needed to use the proper equipment, it is necessary to carry the device by two people. In case of any damages please fill in the damage report in presence of the supplier.

1.3 PACKAGE CONTENT

- destratification fan
- instruction and warranty card

1.4 USE

In the heated high large-spaces the air mass is located in the upper part of room, which causes the heat loss. Destratification fans also called the drop fans or air mixers are used to save on heating. They steer the air back to work zone at the same time they level out the air temperature in the high room, they also limit the heat loss through the roof. They are used in production halls, warehouses and logistic centres.

2. DEVICE CHARACTERISTICS

2.1 CONSTRUCTION AND PRINCIPLE OF OPERATION

Casing: made of expanded polypropylene (EPP). This material is characterized by low density (light weighted) and high chemical and physical resistance. It has an excellent sound and thermal insulation properties. Moreover, material is environmentally friendly and "green", i.e. 100% recyclable.

Diffuser 360°: made of galvanized steel. Using specially shaped air stators the diffuser enables even air distribution in the room.

Axial blowing fan: made of galvanized steel. The objective of the fan is to ensure air flow through the exchanger. It has a single-phase, three speed motor with the following parameters: protection degree IP54, rate current 0.7A-1.08 A (depending on operating mode). Fan has diameter 450 mm.

Rotating mounting bracket (optional equipment): enables the device to be installed in several configurations (depending on the requirements) and the unit to be rotated in a horizontal plane.

2.2 DEVICE DIMENSIONS

- a) wysokość: 698 mm
- b) szerokość: 739 mm
- c) głębokość: 360 mm

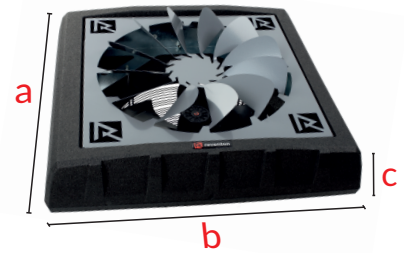

2.3 DEVICE TECHNICAL DATA

TECHNICAL DATA Product code		Destratification fan HC-3S DHC-3S-1766
Maximum airflow [m³/h]	III BIEG	4600
	II BIEG	3900
	I BIEG	3100
Maximum vertical range [m]	III BIEG	10
	II BIEG	8
	I BIEG	6
Supply voltage [V] / Supply frequency [Hz]		230/50
Rated motor current [A]	III BIEG	1.08
	II BIEG	0.86
	I BIEG	0.70
Motor speed [rpm]	III BIEG	1360
	II BIEG	1050
	I BIEG	750
Motor power [W]	III BIEG	240
	II BIEG	190
	I BIEG	160
Protection degree IP [-]		54
Net weight [kg]		11.5
Noise [dB]*	III BIEG	61
	II BIEG	56
	I BIEG	52

* measurement at the distance 5 m

3. ASSEMBLY

3.1. GENERAL PRINCIPLES

During installation, ensure a free air flow to the device and do not restrict the air stream supply. The figures below show the recommended distances between the heater and building partitions:

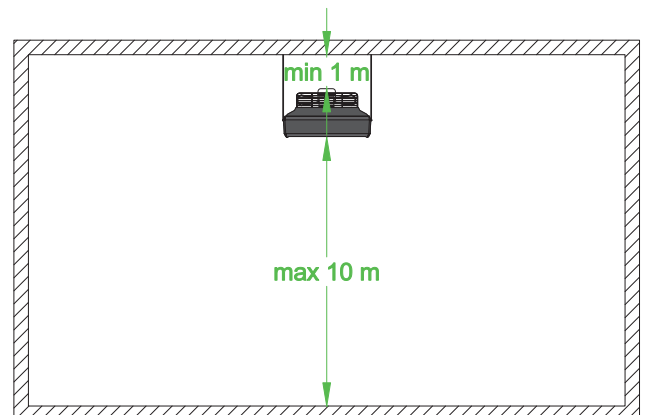

3.2. ROTATING MOUNTING BRACKET

The device can be assembled using a rotating mounting bracket. It enables easy installation of the destratification fan on the ceiling.

4. INSTALLATION INSTRUCTIONS

4.1. CONNECTION OF THE DEIVCE TO THE ELECTRICAL SYSTEM

- all works concerning electrical installation should be made by the qualified personnel (who possess required authorizations to install electrical equipment), based on wiring schematic diagrams (see 7)
- the electrical installation of the building shall have a residual current device
- it is recommended to check the electric installation and controls before the first start

5. PRECAUTIONS & WARNINGS

The precautions mentioned below must be strictly followed during operation of the device:

- all works concerning electrical installation (disassembly, repair etc.) should be made by the qualified staff, who possess the qualifications due to the domestic and local norms, regarding electrical installations
- before service or exchange of the device it is obligatory to cut off the current supply
- do not limit or cover the inlet and outlet of the device
- do not install, service the device with wet hands or barefoot
- the device should be kept out of reach of children and animals
- after operating time of the device, please utilize it concerning the local norms and regulations
- it is recommended to clean the device periodically (at least twice a year):
 - air stators, fan casing and blades clean from dirt
- failure to comply with cleaning obligations may have a negative effect on technical parameters of the device and lead to loss of warranty
- if the device is not used for a longer time and lead to loss of warranty disconnect the voltage supply
- the device is transported with the closed air stators. It is essential to open them in at least for 30% before first start:
 - opening the air stators of the diffuser 360° must be done by two hands in parallel



6. CONTROLS

Usage of automatic control dedicated to the devices of Reventon Group gives great possibilities of adjusting the efficiency of the unit in different, depending on needs, degree of its operation automation. We can offer the following:

3-stage speed controller with thermostat HC-3S

is used to regulate devices equipped with 3-stage fans. It has a 3-stage speed control and built-in thermostat turn on/off the device of automatically when the preset temperature is reached.



Voltage/ Frequency: 230 V AC / 50 – 60 Hz
Maximum current output: 3 A
Temperature range: 10°C - 30°C
Operating mode: continuous or thermostatic
Control accuracy: <1°C
Dimensions: 130 x 85 x 40 mm
Weight: 210 g
Degree of casing's protection: IP 30

Programmable controller HMI

is used to regulate devices equipped with 3-stage fans. It is an advanced controller with many functions i. a. operation in heating, cooling or mixed mode, programmable mode, valve control, automatic selection of the fan speed. Together with the controller an external sensor is provided, which allows to read the temperature in the required place, even remote from the controller. In addition, the device can be integrated with the BMS building control system (using the MODBUS communication protocol).



Voltage/ Frequency: 230 V AC / 50 – 60 Hz
Maximum current: 5 A
Operating temperature range: 0 - 45°C
Regulation range: 5°C - 35°C
Regulation accuracy: ± 0.5°C
External temperature sensor: NTC 10K
Communication: RS485
Dimensions: 86 x 86 x 13.3 mm
Weight: 270 g
Degree of protection (housing): IP 20
Degree of protection (external sensor): IP 68

7. CONNECTION SCHEMES

1. Power
2. Main switch, overcurrent circuit breaker*
3. Destratification fan HC-3S
4. 3-stage speed controllers with thermostat
 - A-work in continuous mode
 - B-operation in thermostatic mode
5. Programmable controller HMI
6. External temperature sensor

*main switch and safety fuses are not included in the set

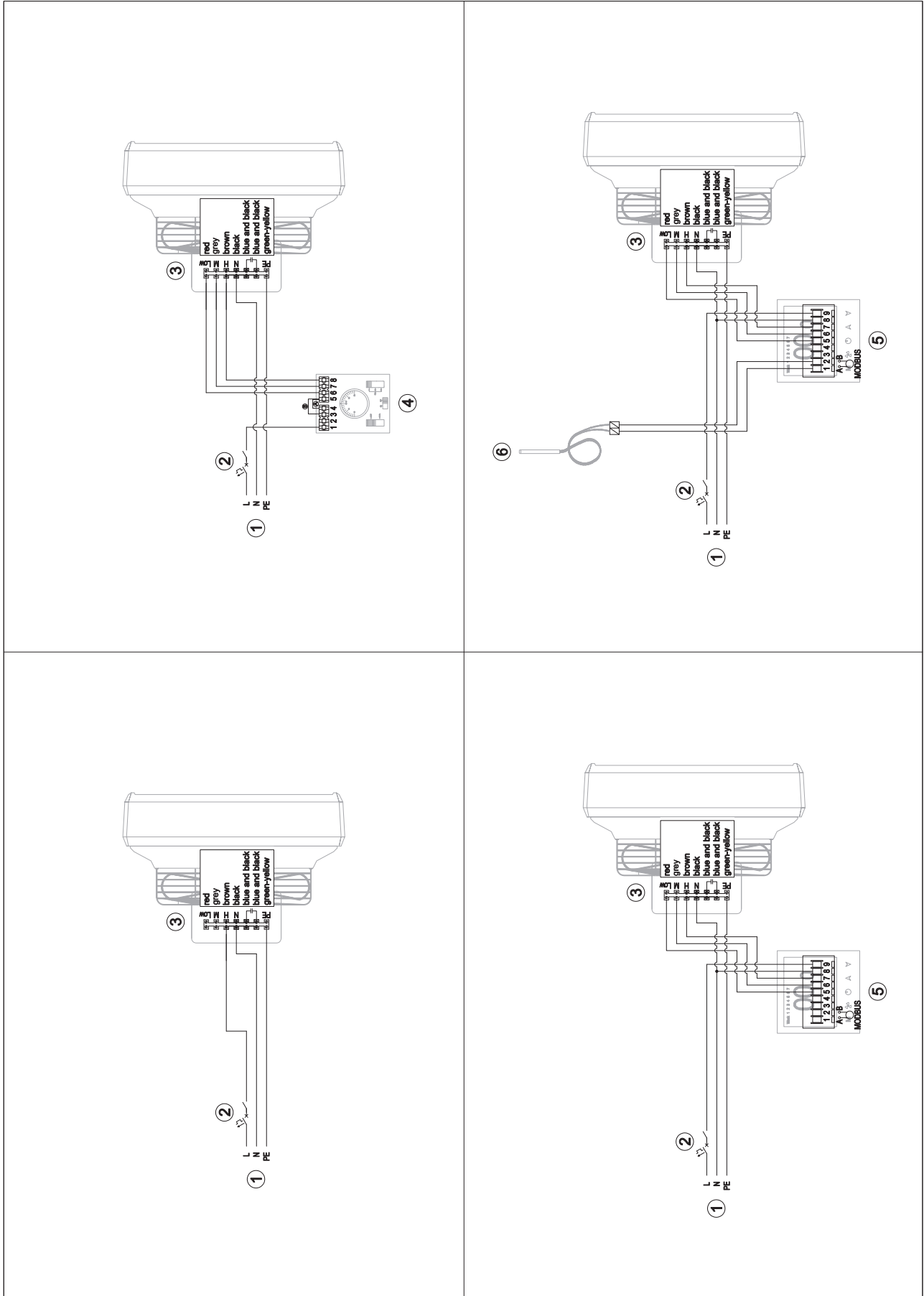

8. TERMS OF WARRANTY

I. Producer Reventon Group Sp. z o.o. [Ltd.] grants the buyer a 24-month warranty period for the following devices:

-destratification fan HC-3S

II. The terms of warranty are valid from purchasing the device (i.e. invoice / another confirming document issue date) but not longer than 30 months from leaving the producer's warehouse.

III. To obtain the service it is needed to provide or send to the producer scans of the warranty card with stamp of installation company, document confirming the purchase (eg. like copy of the invoice) and correctly filled the warranty form.

IV. The producer is committed to consider the claim within 14 working days since the date of reporting (i. e. day when documents given in point III are provided).

V. In the exceptional cases, the producer reserves the right to extend the time limit for examination of warranty, especially if the defect is not permanent and its determination requires a longer period of time. The extension must be notified by the producer before the end of the 14th working day.

VI. Under the guarantee the producer provides a repairment, replacement or refund for the defective device within a specified time limit.

VII. Warranty does not cover the parts of the device subject to normal maintenance and the following cases:

a) mechanical damage of the product

b) defects and damages through:

- improper storage or transport
- improper or non-compliant use and maintenance (i. e. inconsistent with the manual)
- using the device in the improper conditions (too high humidity, too high or too low temperature, impact of the surrounding, sun etc.)
- unauthorized (by the user or other unauthorized persons) repairs, modifications or construction changes
- connecting equipment inconsistent with the technical documentation
- connecting additional equipment, which is not recommended by the producer
- improper power supply

c) elements which wear and tear such as discolor of the housing

If there is any of the above, claimant will be charged for transport and /or repairs.

VIII. Any changes in the Warranty Terms, improper use of the product (careless handling, exposure to liquids, moisture, corrosion), as well as traces of selfrepairing (non by the Reventon Group) or alterations cause, the warranty is not valid.

IX. Not following to any of warranty regulations makes the warranty not valid.

X. All correspondence, returns, complains should be send to the following address: Reventon Group Sp. z o.o. [Ltd.], 556 Wyzwolenia Street, 43-340 Kozy, Poland or email address: serwis@reventongroup.eu.

The producer reserves the rights to make changes to the technical documentation without previous notice.

Warranty card

Factory number of the device:	Address and place of assembly
Stamp and signature of the installation company:	

Warranty form

The company reporting the complaint:	Date of assembly:	Address and place of assembly the device:
The company installing the device:	Date and circumstances of noticing the defect:	
	Factory number of the device:	Date of declaration the complaint:
Description of the defect:		
Contact Name and Surname, telephone number/ e-mail address:		

Service card

Date of declaration the complaint:	Description of the repair:	Service stamp:
Date of repair:		

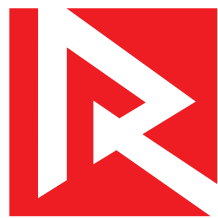

reventon
INDUSTRIAL SOLUTIONS

Reventon Group Sp. z o.o. [Ltd.], 556 Wyzwolenia Street, 43-340 Kozy, Poland, www.reventongroup.eu